



F1-Series

Manual F1-Series analogue input and output modules
Version 1.00

Document conventions

For better handling of this manual the following icons and headlines are used:



This symbol marks a paragraph containing useful information about the device operation or giving hints on configuration.



This symbol marks a paragraph which explains possible danger. This danger might cause a damage to the system or damage to personnel. Read these sections carefully!

Keywords

Important keywords appear in the border column to help the reader when browsing through this document.

MicroControl GmbH & Co. KG
Lindlaustraße 2c
D-53842 Troisdorf
Fon: +49 / 2241 / 25 65 9 - 0
Fax: +49 / 2241 / 25 65 9 - 11
<http://www.microcontrol.net>

1. Safety Regulations	1
1.1 General Safety Regulations	1
1.2 Safety Notice	2
2. Operation of F1-Series	3
2.1 Overview	3
2.2 Available Modules and Accessories	5
3. Connectors and Pinout	9
3.1 CAN/Power connector	10
3.2 Analogue input / Voltage	11
3.3 Analogue input / Current	12
3.4 Analogue input / RTD	13
3.5 Maximum System Configuration	14
3.6 Termination	15
4. Diagnosis	17
4.1 Network Status	18
4.1.1 Representation of CAN state machine	19
4.1.2 Representation of CAN controller state	20
4.1.3 Combined representation	21
5. Configuration Software	23
5.1 Getting started	24
5.2 Configuration	25
6. Technical Data	31
Index	33

1. Safety Regulations



Please read the following chapter in any case, because it contains important information about the secure handling of electrical devices.

1

1.1 General Safety Regulations

This paragraph gives important information about the conditions of use. It was written for personnel which is qualified and trained on electrical devices.

Qualified and trained personnel are persons who fulfil at least one of the following conditions:

- You know the safety regulations for automated machines and you are familiar with the machine.
- You are the operator for the machine and you have been trained on operation modes. You are familiar with the operation of devices described in this manual.
- You are responsible for setting into operation or service and you are trained on repairing automated machines. In addition you are trained in setting electrical devices into operation, to connect the earthing conductor and to label these devices.

The devices described in this manual may only be used for the mentioned applications. Other devices used in conjunction have to meet the safety regulations and EMI requirements.



To ensure a trouble free and safe operation of the device please take care of proper transport, appropriate storage, proper assembly as well as careful operation and maintenance.

Please take care to observe the actual local safety regulations.

If devices are used in a fixed machine without a mains switch for all phases or fuses, this equipment has to be installed. The fixed machine must be connected to safety earth.

1

If devices are supplied by mains please take care that the selected input voltage fits to the local mains.

1.2 Safety Notice

If devices are supplied by 24V DC, this voltage has to be isolated from other voltages.

The cables for power supply, signal lines and sensor lines must be installed in a way that the device function is not influenced by EMI.

Devices or machines for industrial automation must be constructed in a manner that an unintentional operation is impossible.



By means of hardware and software safety precautions have to be taken in order to avoid undefined operation of an automated machine in case of a cable fraction.

If automated machines can cause damage of material or personnel in case of a malfunction the system designer has to take care for safety precautions. Possible safety precautions might be a limit switch or locking.

2. Operation of F1-Series

2.1 Overview

The F1-Series is the right solution for any kind of mobile data acquisition tasks. Available as analogue input and analogue output modules sending and receiving data from the CANbus. As analogue input these modules supply and outrage accuracy and precision.

Also these modules are available with many different kind of digital signals like standard digital IO as well as fast counter input and PWM output.

2



Fig. 1: Four channel analogue input module F1-Series

Use of a fieldbus for signal acquisition and signal generating has the advantage of reduced costs because expensive I/O cards for a PLC or PC can be omitted. In addition, the design of an application is more flexible and modifications are more easily to achieve.

2

The development in automation towards decentralized „intelligent“ systems makes the communication between these components quite important.

Modern automated systems require the possibility to integrate components from different manufacturers. The solution for this problem is a common bus system.

All these requirements are fulfilled by the F1-Series module. The F1-Series runs on the standard fieldbus CAN.

Typical applications for the F1-Series are industrial automation, transportation, food industry and environmental technology.

space saving and compact

The F1-Series is designed for heavy duty applications. The aluminium cast ensures protection class IP66. The compact, space saving case gives the freedom to mount the module in many places.

cost-effective and service friendly

The quick and easy integration of the F1-Series in your application reduces the development effort. Costs for material and personnel are reduced. The easy installation makes maintenance and replacement quite simple.

2.2 Available Modules and Accessories

In the following table the list of available IO modules can be seen. This table only shows the standard F1-products. Many customer specific solutions have already been manufactured - please ask us for further information.

F1 Module	Signals
4 x Analogue Input / Volt	+/-10V, +/-40V
4 x Analogue Input / Ampere	0..20mA, 0..100mA
4 x Temperature Input / TC	Type J,K,L,R,S,T (with CJC)
4 x Temperature Input / RTD	Pt100, Pt500, Pt1000
4 x Strain Gauge	Full Bridge
4 x Analogue Output	+/-10V, 0..20mA
8 x digital IO	1,4A per Output / Digital Inputs
4 x digital counter	Counter up to 500kHz, A/B signals

Table 1: List of available functionalities

The available accessories are cable sets and connectors for the signal inputs.

- Inter Module Connector

F1/F1 connector (CAN + Power), length 140mm, Lemo B series connectors (male)



Fig. 2: These connectors are used to directly interface 2 or more F1-modules.

- F1 external connector

F1 cable connector 2mtrs. with Lemo B Series connector (to F1) and open wire (to interface of any other system). Also available in different lengths.



Fig. 3: These connectors are used to interface any other CAN units such as data loggers / PCs / Laptops

- F1 CAN termination

F1 termination for the CANbus interface



Fig. 4: The CANbus needs to be terminated at both ends of the line

- F1 sensor connector
- F1 CAN + Power connector

Straight Plug, FGG.0K.306.CLAC50, 6-pole, solder contacts (Sensor connector)

Straight Plug, FGN.0F.305.XLC, 5-pole, solder contacts (CAN / Power connector)



Fig. 5: Connector for interfacing analogue signals to the module

- F1 sensor connector with open wire

Straight Plug, FGG.0K.306.CLAC50, 6-pole, solder contacts (Sensor connector), 2mtrs. of sensor wires, open ended



Fig. 6: Connector for interfacing analogue signals to the module



3. Connectors and Pinout

This chapter contains the information for the complete range of different connectors used with the F1-Series. In the following figure there is shown the standard mechanical outfit of the F1-Series housing.

Additional to the connectors there can be seen a bi-color LED which shows the module status.

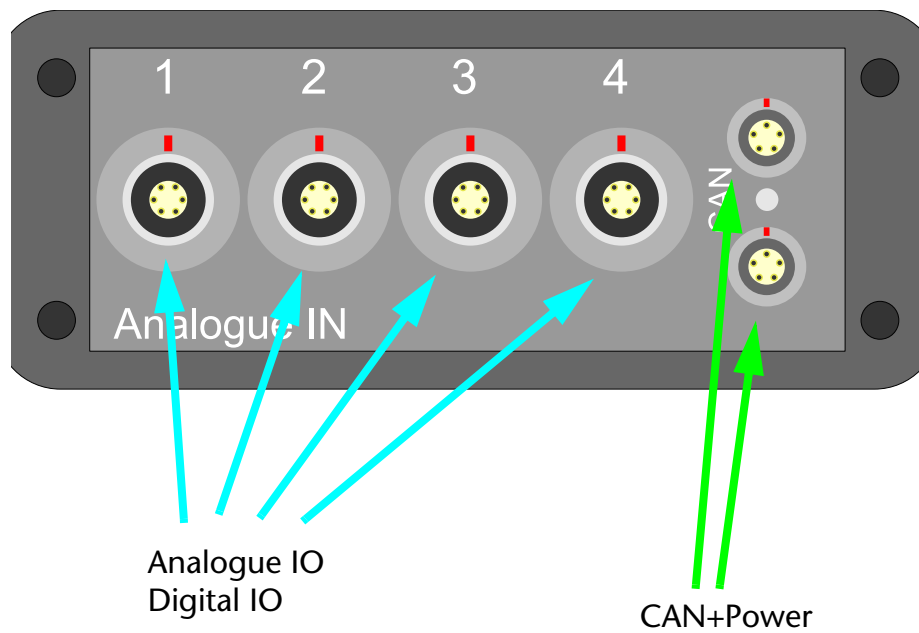

3.1 CAN/Power connector

The following figure shows the power+CAN connector of the F1-Series modules. Use the figure to identify the pins and the according functionality.

3

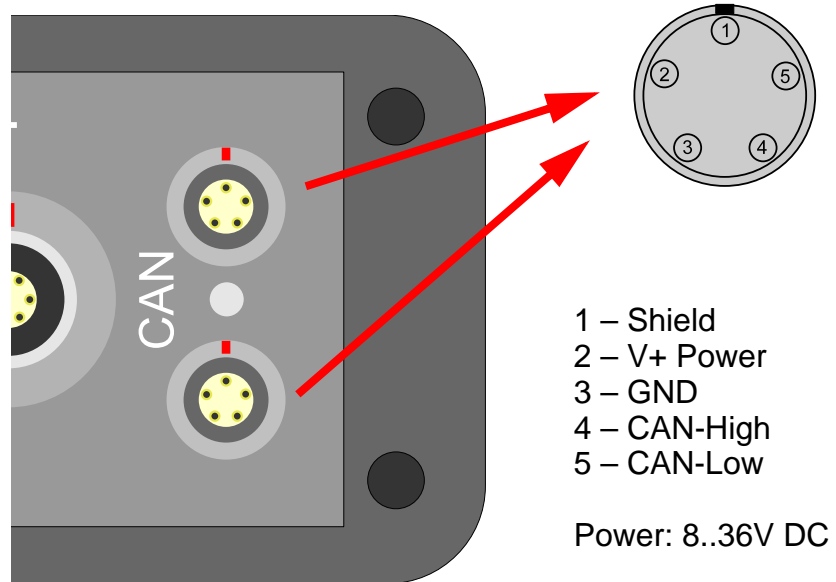
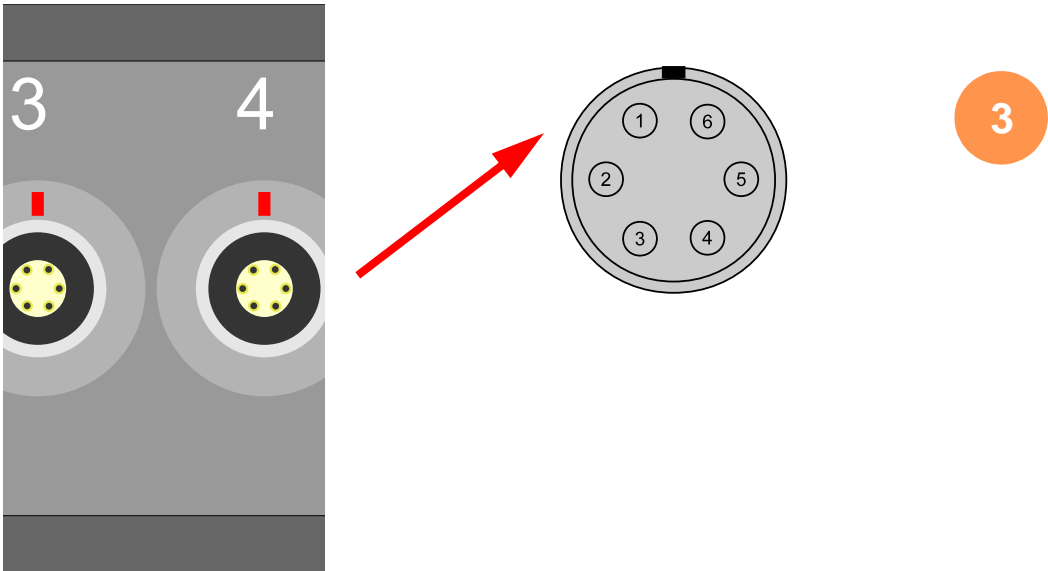

Fig. 7: CAN+Power connector pinout

3.2 Analogue input / Voltage

The following figure shows the analogue input connector of the F1-Series modules. Use the figure to identify the pins and the according functionality.



Voltage Input
+/-40 V

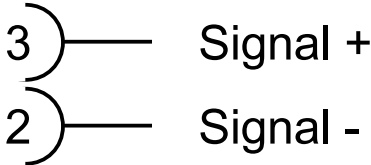
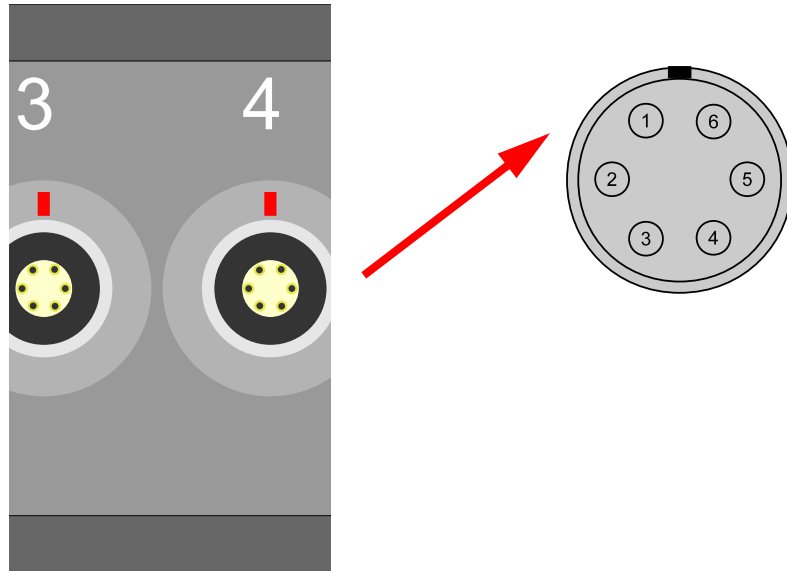

Fig. 8: Analogue input connector (voltage) pinout

3.3 Analogue input / Current

The following figure shows the analogue input connector of the F1-Series modules. Use the figure to identify the pins and the according functionality.

3



Current Input
0(4)..20mA

5) — Signal +
4) — Signal -

Fig. 9: Analogue input connector (current) pinout

3.4 Analogue input / RTD

The following figure shows the analogue input connector of the F1-Series modules. Use the figure to identify the pins and the according functionality.

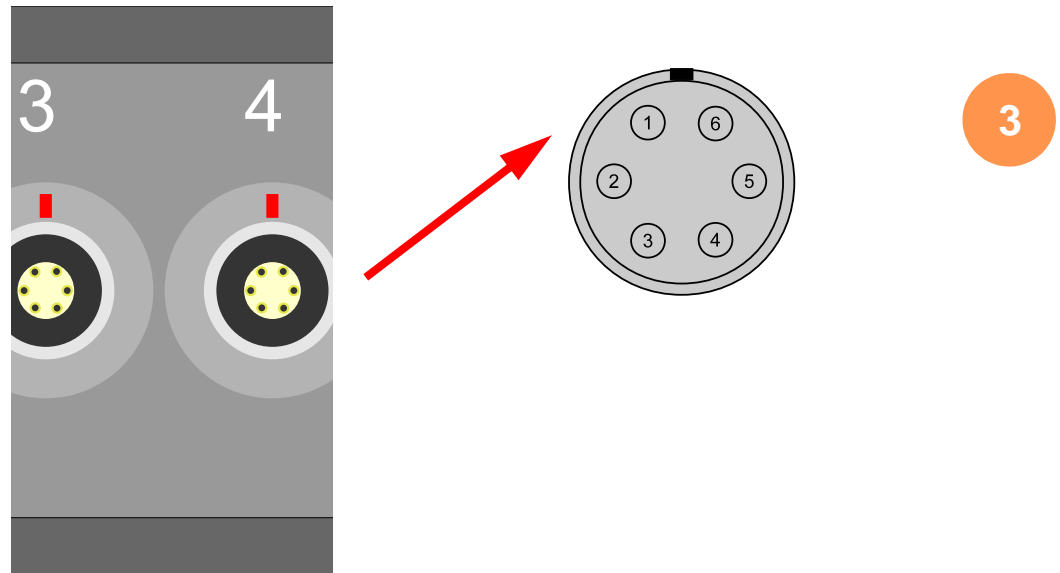

Pt Input Pt100 / Pt500 / Pt1000

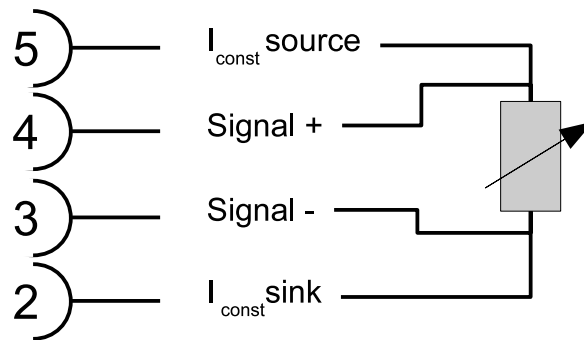

Fig. 10: Analogue input connector (RTD / Pt100) pinout

3.5 Maximum System Configuration

The maximum cable length depends on the selected baudrate. The following table shows the maximum cable length recommended by the CAN in Automation (<http://www.can-cia.org>). These distances can be realized with the F1-Series.

Baudrate	Cable length
1000 kBit/s	25 m
800 kBit/s	50 m
500 kBit/s	100 m
250 kBit/s	250 m
125 kBit/s	500 m
100 kBit/s	650 m
50 kBit/s	1000 m
20 kBit/s	2500 m

Table 2: Dependence of baudrate from cable length

3.6 Termination

The modules at both ends in the CAN network have to be terminated with a resistor of 120 ohms. That means the modules at the end of the bus line are not reflecting back power and the communication can not be disturbed.

For termination of the F1-Series can be set by using the appropriate connector.



Please make sure that only the devices at both ends of a CAN bus are terminated. In un-powered condition the correct termination value is 60 Ohm between the lines CAN-H and CAN-L.

3



Abb. 11: Termination of CAN bus



4. Diagnosis

All modules of the μ CAN family have LEDs to display the operating state and to signalize an error state.

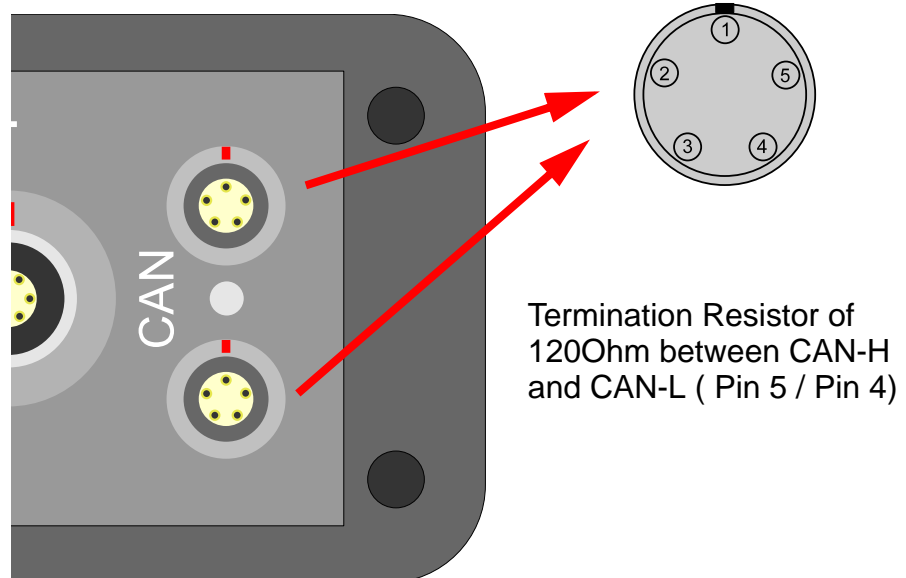
The F1-Series has one bi-color LED (green/red) labeled with "CAN" (Network Status).



Abb. 12: Position of LEDs on the module



In normal operation all LEDs should have a green or orange color. A red steady light or a red blinking of a LED indicates an error condition.

4.1 Network Status

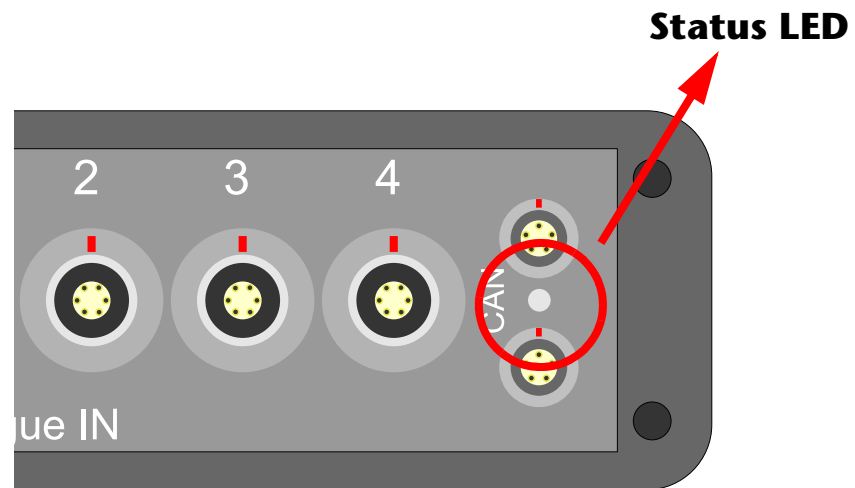
The bi-color LED labeled with "CAN" shows the status of the CAN state machine as well as the error state of the CAN controller.

4.1.1 Representation of CAN state machine

The green light represents the status of the CAN network management state machine.

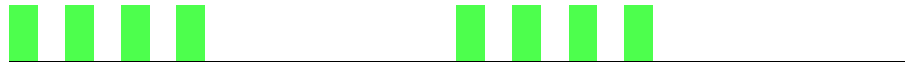

Initialisation (Autobaud detection)



device is "stopped"



device is "initializing"



device is "operational"



4.1.2 Representation of CAN controller state

The red light of the NS-LED represents the error state of the CAN controller. The red light is off during error-free condition.

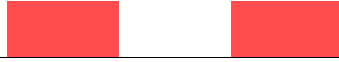

CAN status: controller in "warning" state



CAN status: controller in "error passive" state



CAN status: controller in "bus-off" state

4.1.3 Combined representation

The combination of the green light and the red light of the NS-LED allows the representation of both - the NMT status and the CAN controller status. The following pictures give an example of combined representation.



Device in "initializing" state, CAN controller in "warning" state



Device in "operational" state, controller in "error passive" state





5. Configuration Software

The F1-Series modules are configured via software and the CAN-bus interface. For configuration purposes there is a free software available which can be downloaded at:

http://www.microcontrol.net/download/software/f1control_install.exe/

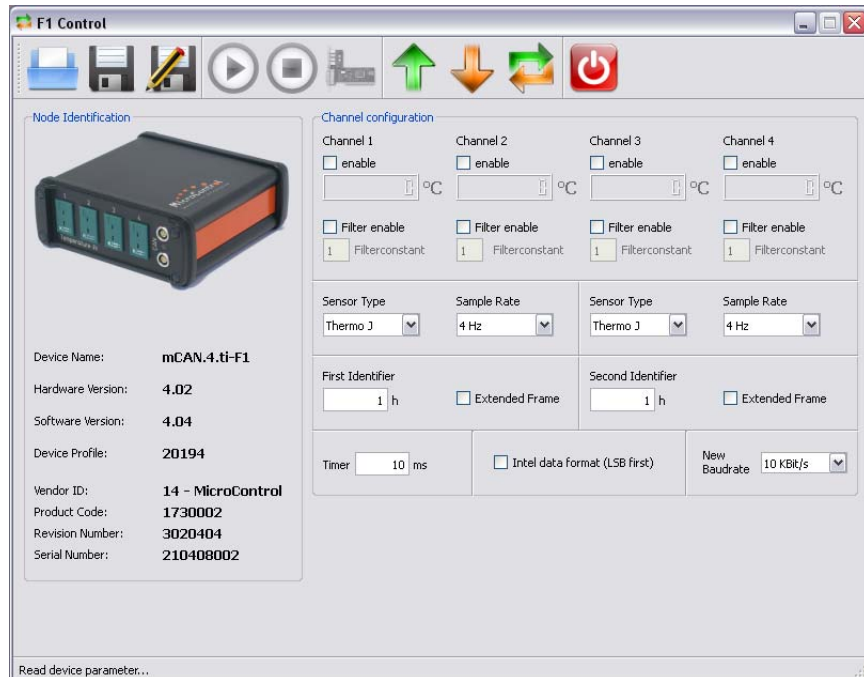

5.1 Getting started

As first step the software has to be started and the "scan for devices" button has to be activated.

Then the F1-module has to be powered up.

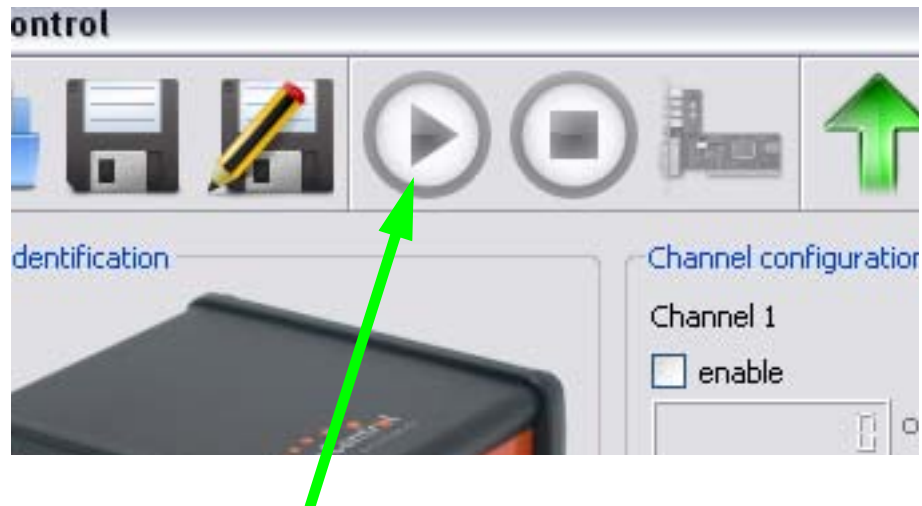

5

First press this button to start the scan process for a connected device
then
power up the F1-module

Abb. 13: Starting the scan process

If there is no device connected, or unintentionally the device has been powered up before pressing the "Start scan" button, only by pressing the "Stop" button the software will stop scanning.

After a device has been identified by the configuration software, the module description and some basic parameters can be seen on the left side of the configuration software.

5.2 Configuration

After having found the connected module, some basic parameters can be seen.

Now the configuration software has complete control over the module and the configuration can take place.

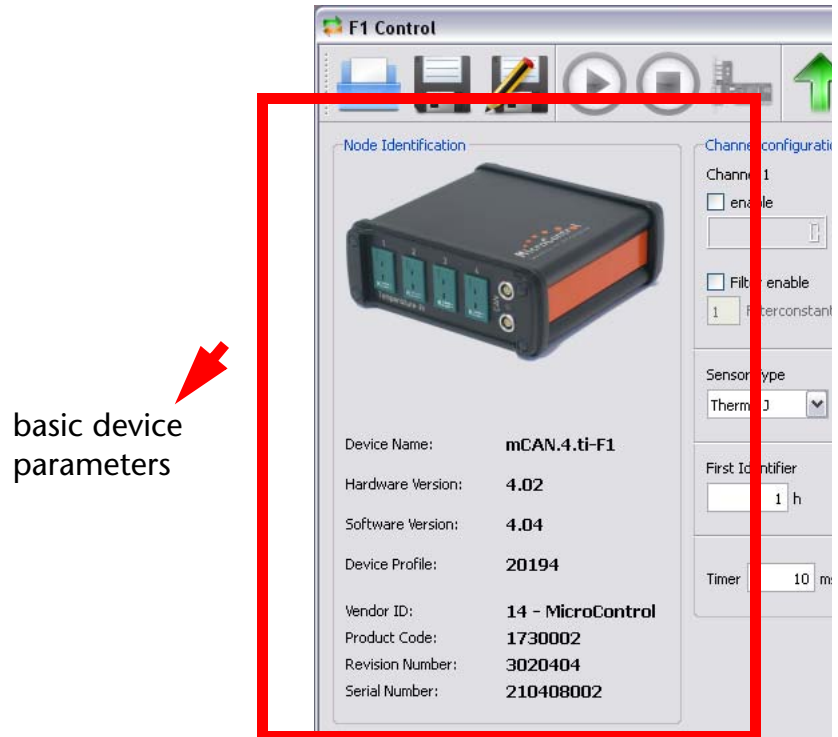

5

Abb. 14: Basic device parameters

switching on / off channels

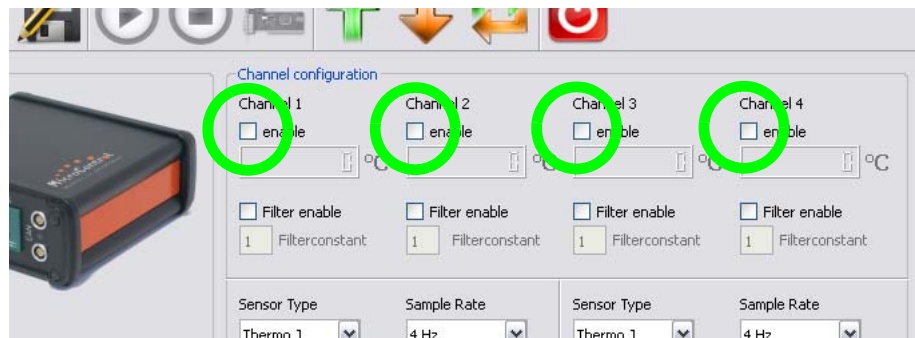

By means of these switch boxes channels can be switched off.

If there are channels not being used, we recommend to switch them off.

setting a filter constant

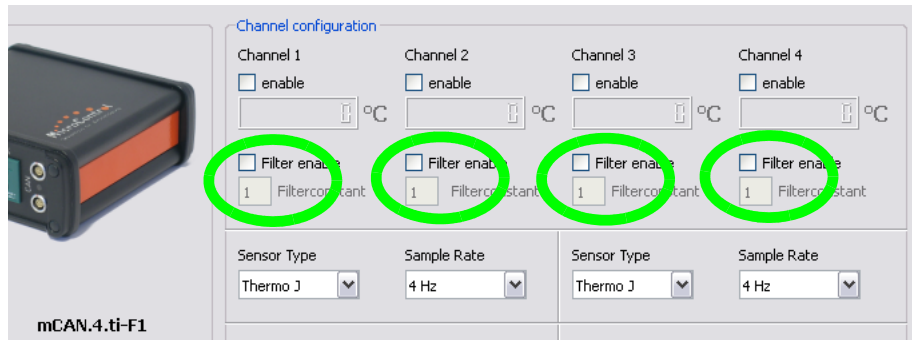

Filter-Routine:

$$act = act + 1/Filter\ Const * (new-act)$$

$$act = new$$

with:

act = last measuring value

new = new measuring value

5

By means of the filter switch boxes and parameter a software filter can be selected for each input individually. If the filter is switched off, there will be no internal software filtering.

sensor type and sample rate

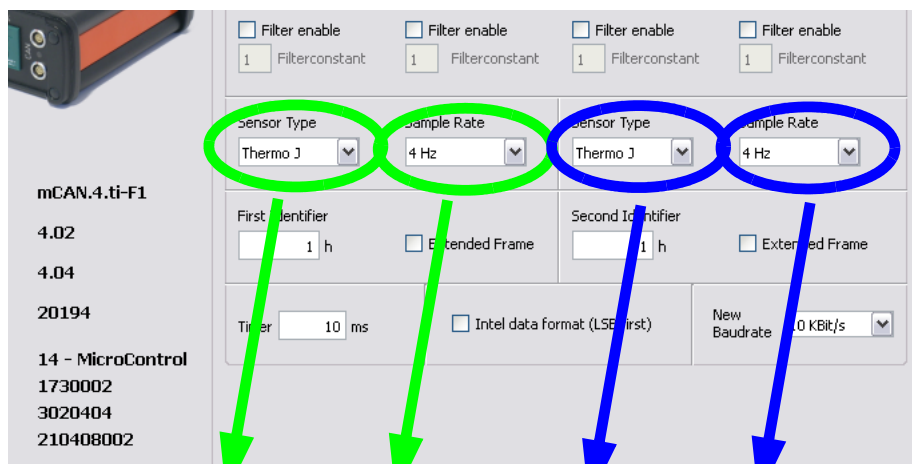

Sensor type and sample rate for inputs 1+2

Sensor type and sample rate for inputs 3+4

Input pairs 1+2 and 3+4 can be configured individually for different sensor types and sample rates.

Attention: The selected sample rate is independant from the selected Timer of the message transmission rate.

Identifier selection

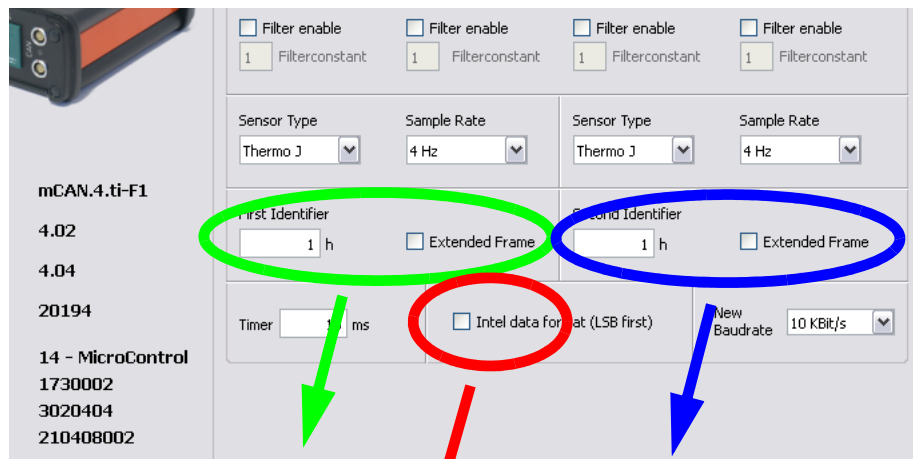

Identifier selection for inputs 1+2

Identifier selection for inputs 3+4

Byte order selection for all inputs

5

Each pair of measuring values from inputs 1+2 and inputs 3+4 are transmitted individually in a Tx-message on the CANbus.

So for each pair of inputs a different CAN-Identifier can be selected. Also the transmission of Extended-Identifiers (29-bit ID) is supported.

As transmit message for the measuring values the F1-Series will send the following messages:

ID	DLC	B0	B1	B2	B3	B4	B5	B6	B7
xx	8	Signed 32bit, Input 1				Signed 32bit, Input 2			

:

ID	DLC	B0	B1	B2	B3	B4	B5	B6	B7
yy	8	Signed 32bit, Input 3				Signed 32bit, Input 4			

The byte order is by default MSB / LSB and can be reversed by means of the according button.

Identifier selection

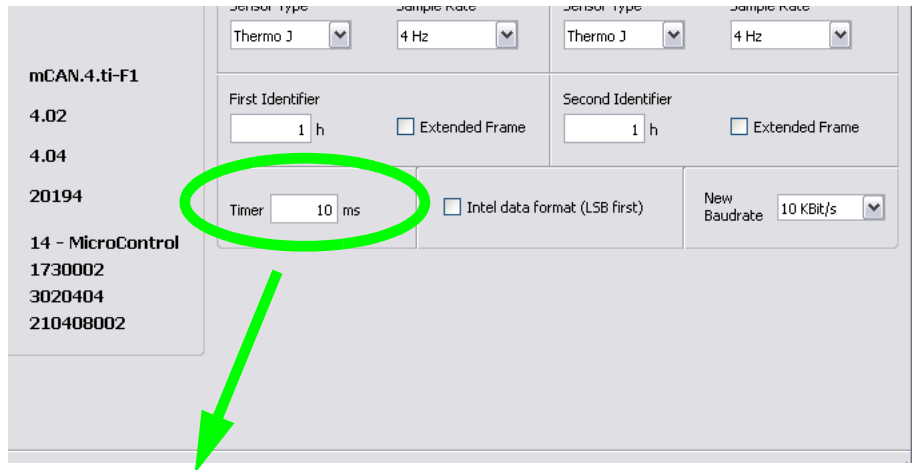

Timer configuration for the transmission rate

5

The transmission rate (Timer) of the messages is independent of the selected sample rate of the module. The transmission rate is always valid for both Tx-messages.



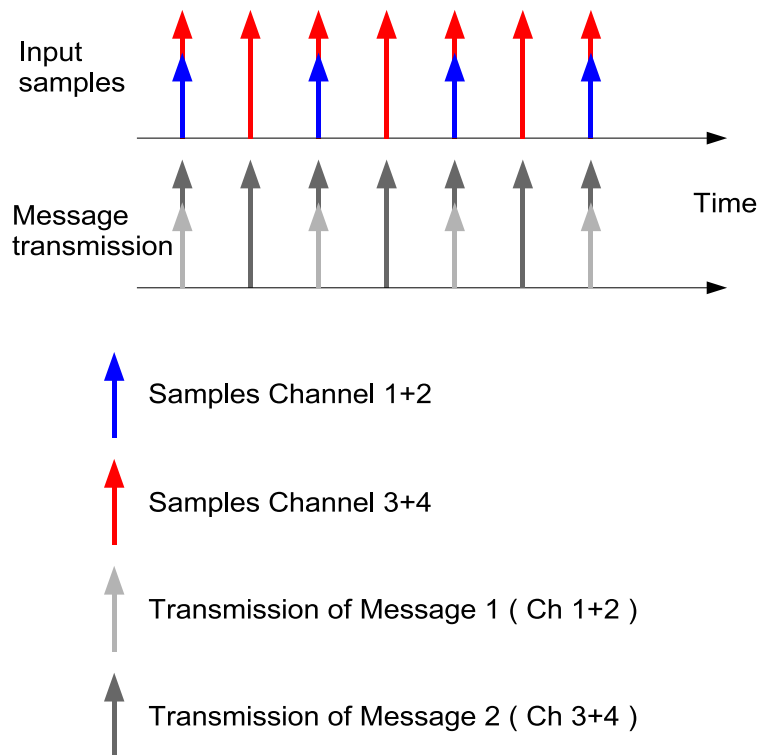

Only when selecting the transmission rate (Timer) to be 0, the transmission of messages will take place in the selected sample rate of the analogue inputs.

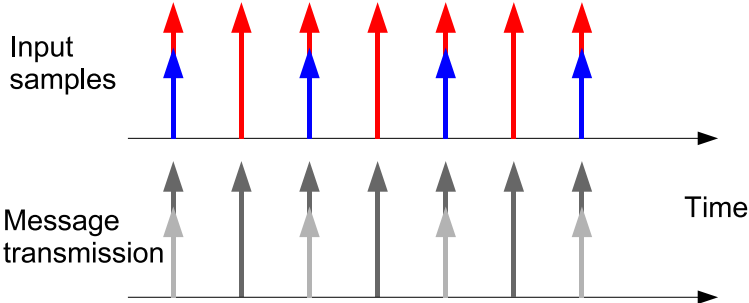

When selecting a Timer value $\neq 0$ the transmission of messages and the input sampling is not synchronized.

When selecting a Timer value = 0 the transmission and the sampling of the inputs is synchronized.



-  Samples Channel 1+2
-  Samples Channel 3+4
-  Transmission of Message 1 (Ch 1+2)
-  Transmission of Message 2 (Ch 3+4)

5

6. Technical Data

Power Supply	
Supply Voltage, U_{PWR}	12 .. 36 V DC, reverse current protected
Power Consumption	1,5 W (60 mA @ 24 V DC) without load
Isolation	Fieldbus/Supply: 500 Veff
Isolation	Analogue Output Block/Supply: 500 Veff
Physical Interface	Lemo connectors

CAN-Bus	
Baudrates	20 kBit/s .. 1 MBit/s
Status on the bus	active node
Protocol	RawCAN / CAN / CANopen (on request)
Physical Interface	Lemo connectors

EMC	
Electromagnetic immunity	according to EN 50082-2
Electrostatic discharge	8 kV air discharge, 4 kV contact discharge, according to EN 61000-4-2
Electromagnetic fields	10 V/m, according to ENV 50204
Burst	5 kHz, 2 kV according to EN 6100-4-4
Conducted RF-Disturbance	10 V, according to EN 61000-4-6
Electromagnetic emission	according to EN 50081-2



Mechanic	
Case	Aluminium
Dimensions	120x110x48mm (LxBxT)
Weight	approx. 600g
Protection class	IP66

Analogue Inputs / Voltage	
Impedance	200 kOhm
Signal Span	-40V .. +40V DC
Resolution	21bit
Accuracy (@ 23°C)	0,01% of Span End

Analogue Inputs / Current	
Impedance	50 Ohm
Signal Span	-20mA .. +20mA DC
Resolution	21bit
Accuracy (@ 23°C)	0,01% of Span End

Temperature Inputs / RTD	
Impedance	200 kOhm
Signal Span	-150°C ... +850°C
Resolution	21bit
Accuracy (@ 23°C)	0,01% of Span End

Analogue Outputs / Current	
Impedance	max. 500 Ohm
Signal Span	0 .. 20 mA DC
Protection	Short Circuit protected
Resolution	16 bit
Accuracy (@ 23°C)	0,01% of Span End

6

Index

B

Baudrate
bus length 14

C

Cable length 14

N

Network Status
LED 17

T

Termination 15

MicroControl reserves the right to modify this manual and/or product described herein without further notice. Nothing in this manual, nor in any of the data sheets and other supporting documentation, shall be interpreted as conveying an express or implied warranty, representation, or guarantee regarding the suitability of the products for any particular purpose. MicroControl does not assume any liability or obligation for damages, actual or otherwise of any kind arising out of the application, use of the products or manuals.

The products described in this manual are not designed, intended, or authorized for use as components in systems intended to support or sustain life, or any other application in which failure of the product could create a situation where personal injury or death may occur.

No part of this documentation may be copied, transmitted or stored in a retrieval system or reproduced in any way including, but not limited to, photography, magnetic, optic or other recording means, without prior written permission from MicroControl GmbH & Co. KG.

© 2009 MicroControl GmbH & Co. KG, Troisdorf



Systemhaus für Automatisierung

MicroControl GmbH & Co. KG

Lindlaustraße 2c

D-53842 Troisdorf

Fon: +49 / 2241 / 25 65 9 - 0

Fax: +49 / 2241 / 25 65 9 - 11

<http://www.microcontrol.net>